

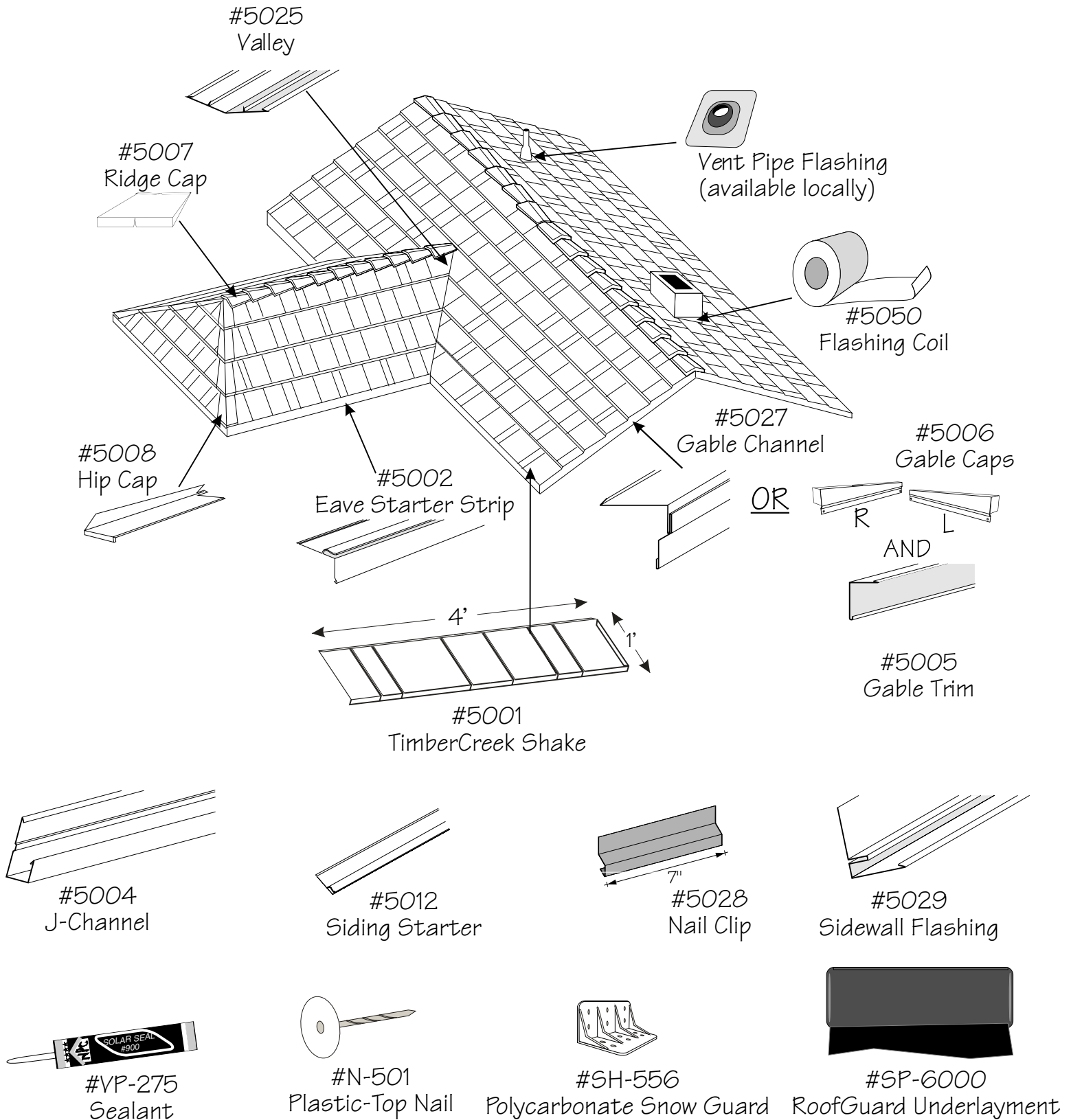

**CLASSIC
PRODUCTS**
INC.

TimberCreek Shake INSTALLATION INSTRUCTIONS

For further installation details, call the factory at 1-800-543-8938.



GENERAL GUIDELINES

This manual describes basic installation procedures for the TimberCreek Shake steel roofing system. This is a battenless, concealed fastener roofing system which installs over solid decking or existing roofing. In all instances, underlayment must be installed as described below.

TimberCreek Panels and accessories, before installation, should be stored in a dry area with proper ventilation which does not allow condensation or other moisture to form on the products.

The minimum required roof pitch is 3:12. Classic Products' ClickLock Premium Standing Seam is available for lower pitch applications. Use ringshank galvanized or stainless steel roofing nails or screws. Fasteners should be long enough to fully penetrate sheathing or at least 1" into solid lumber. Do not allow copper, aluminum or other dissimilar metals to come in contact with the TimberCreek Shake roofing system. Always separate metals from masonry using underlayment or roofing cement.

Installer is responsible for ensuring that all appropriate local and national building code and safety requirements are met. In some cases, this may involve special underlayment or installation procedures.

SPECIAL INSTALLATION NOTES

Letters to the right of each heading refer to these notes

A

This flashing has a return flange to act as a channel for water to run down the roof under the shingles. Be careful not to flatten this return flange. No nails should penetrate the flashing within this channel area. Fasten the flashing to the roof with Nail Clips 16" on center. Also, the shake at the bottom of this channel should be notched to allow the water to run out. Shakes should be secured with a Nail Clip outside the return flange.

B

Install shakes into this flashing with a ¼" gap between the edge of the shake and the inside of the flashing, to allow water to run down the roof.

C

If starting shakes out of this flashing and proceeding to the left, remember to stagger succeeding courses with full, ½, ¾ and ¼ shakes.

D

Uphill flashings should nest inside or lap downhill by 6" and be sealed with Sealant (VP-275).

Installation Sequence

1. Prepare roof and apply underlayment.
2. Install **EAVE STARTER STRIP**.
3. Install **GABLE CHANNEL, VALLEYS, and FLASHINGS**.
4. Install **SHAKES**, left to right, eave to ridge, and **HIP CAPS**.
5. Install **RIDGE CAPS**.

Roof Preparation

Shakes may be installed over solid sheathing, old composition shingles, or thin (maximum ¾" butt) wood shingles. If it meets local building codes, shakes may also be installed over spaced sheathing by installing additional lathe boards as needed for fastening of new roof. To prepare for reroofing, nail down any loose or curled shingles and protruding nails, cut off overhanging shingles and remove any ridge or hip caps. When installing over wood shingles, cut back the shingles 4" from eaves and gables and fill this area with new lumber. Sweep the roof clean. Shakes may not be installed over thick wood shakes, tile, cement shakes, or metal.

Underlayment

Cover entire roof with SP-6000 or other underlayment (minimum 30 lb. felt). Allow underlayment to overhang eaves by 1½", and extend up pipes and penetrations by 1½". Lap head and end joints 6", lap successive courses 4". Fasten on 12" centers using Plastic-Top Felt Nails (N-501). On installations over spaced sheathing, underlayment must be installed on top of lathe boards. As an option for areas with heavy ice and snow potential, use ice & water shield or similar underlayment above overhanging eaves plus two feet past exterior wall lines. Additional underlayments may be required to meet local codes.

Eave Starter Strip (5002)

Fold 1½" overhanging underlayment against fascia and apply Starter Strip (5002) at the eaves. Nail to roof deck 16" on center. At corners, snip the drip edge lower bead and top lock to bend Starter Strip around corner. Join two Starter Strips together by snipping 1" from top lock and sliding the two parts together, nested inside each other.

Gable Channel (5027)

A C D

Plumb cut the trim lower end, and snip to accommodate Starter Strip. In areas of high wind potential, face nail the drip edge to gable fascia. Install Gable Channel (5027) using Nail Clips 16" on center, with three nails per clip. Install shake panels by cutting shake on an angle to allow 1¼" overhanging gable at uphill corner of shake and 2¼" overhanging at lower butt corner. Cut shake top and bottom locks as well as shake butt even with gable. Bend excess "pie shaped" piece downward 90 degrees to receive into Gable Channel. If fold intersects a deep groove in panel, flatten deep groove as necessary. When starting shingles out of a gable, the stagger should be set to avoid having to bend over the deep grooves. When ending into a gable, the installer can sometimes avoid bending over deep grooves by inserting a specially-formed narrow shake panel before the end panel. Install shake panel by using a nail clip just outside of the Gable Channel's water channel. Install subsequent courses using full, ½, ¾, ¼ pattern. Notch away butt lock of lowest course where it overlaps the Gable Channel's water channel so water can drain out at bottom (See Illustration 1).

OR:

Gable Trim & Gable Caps (5005 & 5006)AC

Install Gable Trim (5005) with nail clips 16" on center to the roof deck. Install shakes to overhang the gable edge by ¾". After shake installation, Gable Caps (5006) are applied

to the ends of the shakes and nailed to gable fascia through pre-punched holes, or riveted to shakes or Gable Trim. At the ridge, Gable Trim from one side should be bent down and lapped over the other.

Sidewall Flashing (5029) A B C D

Sidewall Flashing (5029) is a "J" channel with a return flange on the roof deck and a leg extending up the wall which should be inserted behind the sidewall covering. It is installed using Nail Clips 16" on center with three nails each. If the flashing cannot go behind the siding, nail it to the sidewall and seal, or secure to wall with terminator bar and seal. Notch the bottom shake butt to allow water to drain out. If the sidewall is masonry, treat as chimney side flashing, below (see **Illustration 3**).

Valley (5025) A C D

Prepare the valley by laying a full width of underlayment down the valley, using Plastic-Top Felt Nails (N-501). Chalk the center line of the valley, and lay Valley (5025). Trim Valley $\frac{3}{4}$ " past the eave and fold into Eave Starter Strip. Top of Valley pan should overlap top of valley by 4" and be folded down. It is installed using Nail Clips 16" on center with three nails each. Run Valley in one length if possible, or lap uphill portions 6" to 10" over downhill portions and seal. Shakes must be cut and bent to lap the Valley ridge dams. When a shake course reaches the valley, the shake that runs into the valley must be trimmed and folded over the Valley ridge dam (the raised fold between the middle of the valley and the return flange). The shake should be marked $\frac{3}{4}$ " past the ridge dam at the top of the shingle, and $1\frac{3}{4}$ " past it at the bottom of the shake. Draw a line to connect these marks, and cut. Then fold the resulting angled flange down over the Valley ridge dam, so that the bottom of the flange laps the flange of the shake below it (see **Illustration 4**).

TimberCreek Shake (5001)

Begin shake installation at lower left corner. Slide bottom lock of shake into Eave Starter Strip (5002) and slide to gable. Make certain that panel interlocks are fully engaged. Install shakes using three Nail Clips per shake, 16" on center, each fastened with four nails. On installations over wood shingles on spaced sheathing, the Nail Clip can be used on the right-hand lock at a level which allows secure fastening through the old shingles and into a lathe board.

Continue installing shakes left to right, eave to ridge, by engaging the bottom and left locks to surrounding shakes and/or Eave Starter Strip. For maximum wind resistance and to avoid a "pattern" appearance on the roof, successive courses are staggered by starting with $\frac{1}{2}$, $\frac{3}{4}$ and $\frac{1}{4}$ shakes. The fifth course from the eave should start with a full shake, then the pattern repeats. Cut shake panels using snips or guillotine. For maximum performance, cut edges should be sealed with rust-inhibiting paint.

Chimney Flashing A C D

Make a $\frac{1}{2}$ " cut in the masonry above existing flashings and parallel to the roof deck. On the downhill side of the chimney, field-form a flashing to be received into this cut,

extend down to the roof deck and 4" out on top of the installed shakes below. On sides of chimney, field-form flashings (or use 5029 Sidewall Flashing) to be received into the cuts, extend down the chimney and 6" out onto the deck, with a $\frac{1}{2}$ " return flange. Shakes are butted against chimney side flashing and sealed. The downhill ends of chimney side flashings should rest on top of the downhill chimney flashing. The uphill side of the chimney should be cricketed and a flashing should be formed to be received into the $\frac{1}{2}$ " cut, extend down over the cricket, and rest on top of the chimney side flashings. The uphill portion of this flashing should lay beneath the shakes above (see **Illustration 2**).

Vent Pipe Flashing A D

Use standard galvanized steel and neoprene vent pipe flashings, available locally. Bring underlayment $1\frac{1}{2}$ " up around pipe, and add an additional piece of underlayment extending 18" to each side, the downhill side of which should rest on top of the shakes beneath the vent pipe flashing. Seal underlayment seams, especially around pipe, with roofing cement or VP-275 Sealant. Bend $\frac{1}{4}$ " return flanges on the sides and top of the flashing. Install the vent pipe flashing when enough shingles have been installed that the bottom of the flashing will lay on top of shakes below. Fasten the flashing with Nail Clips attached to the return flanges. Then install shakes around the pipe, cutting as necessary to allow only the pipe and neoprene boot to show (see **Illustration 6**).

Hip Caps (5008) C

Where the shake reaches hip line, cut to angle at hip line. Use a Nail Clip on shake top lock at the hip. Hip Caps (5008) are installed by locking the front edge of each hip cap onto the butt edge of the shakes on either side of the hip. The top lock of the shake is slit just enough to allow the Hip Cap to extend its full length up the roof. When you install the next course of shakes above the Hip Cap, face-nail through the shake into the cap below, with three nails on either side of the hip line. These nails should be in a part of the shake which will be covered by the next Hip Cap to be installed. In instances of mis-matched roof pitches, consult the manufacturer on how to use Ridge Caps in place of Hip Caps (see **Illustration 7**).

Ridge Caps (5007)

The ridge must be watertight before installing Ridge Caps. Either: 1) bend the top course of shakes over the shakes on other side of ridge by at least 2" or 2) field-form a flashing to make the ridge watertight. Install a field-formed starter piece on the ridge at the gable end to lock the first cap over. Install Ridge Caps by engaging back flange into front flange of previously-installed caps. Fasten with one Nail Clip, notched in its center so that it folds over the ridge and attaches firmly to the Ridge Cap flange on both sides. Ridge Caps may be started at both gable ends and work toward the middle, where a trimmed cap attached with sheet metal screws will join them. Seal screw heads (see **Illustration 5**).

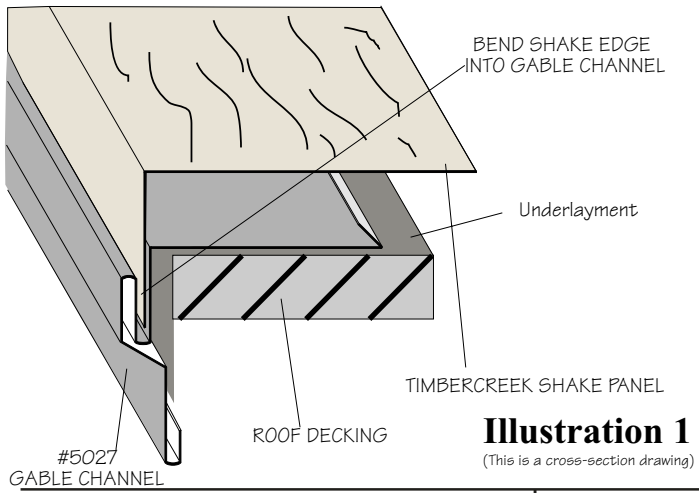

Illustration 1
(This is a cross-section drawing)

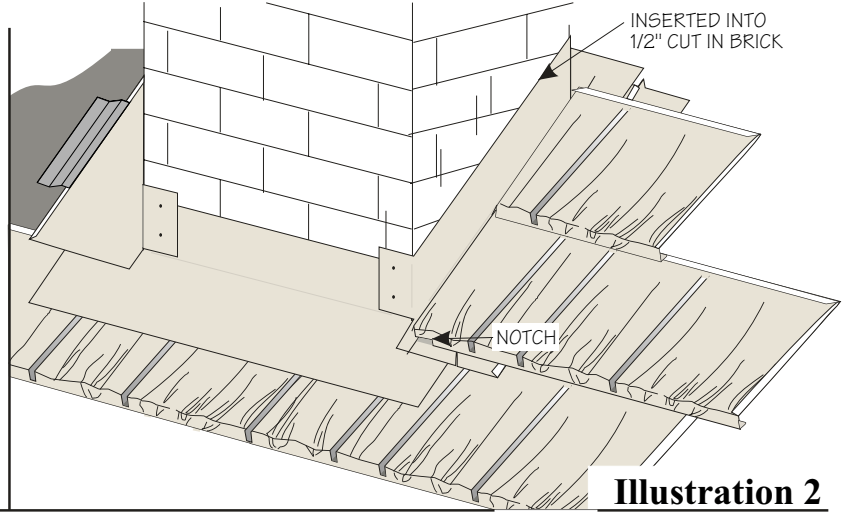

Illustration 2

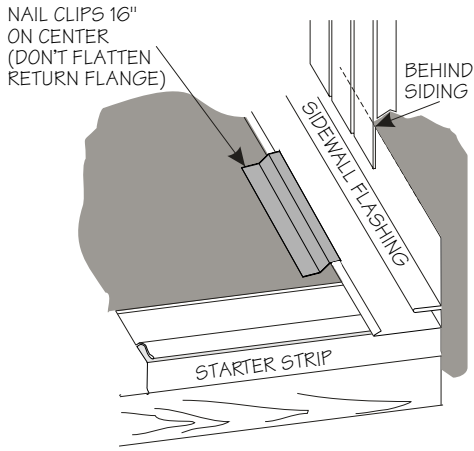

Illustration 3

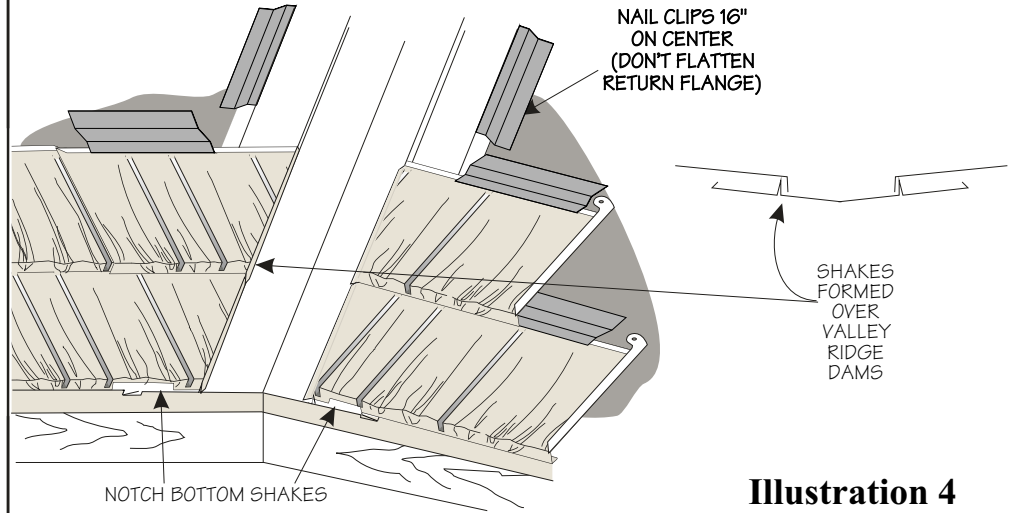
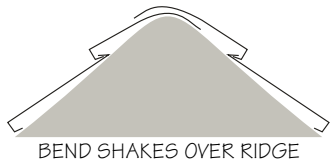

Illustration 4

MAKE RIDGE WATERTIGHT BEFORE INSTALLING RIDGE CAPS:



-OR-

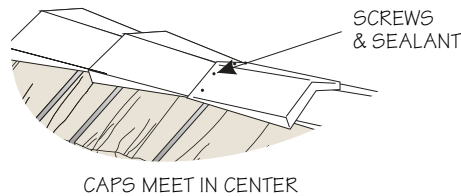
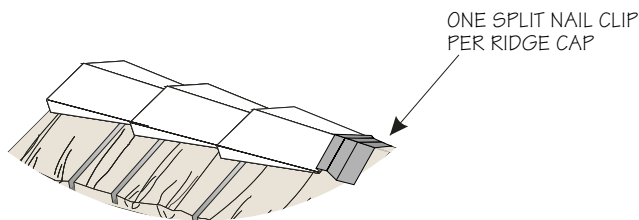
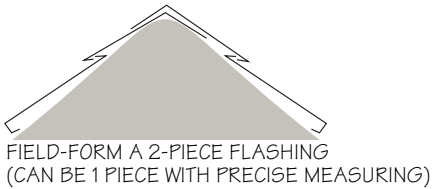

Illustration 5

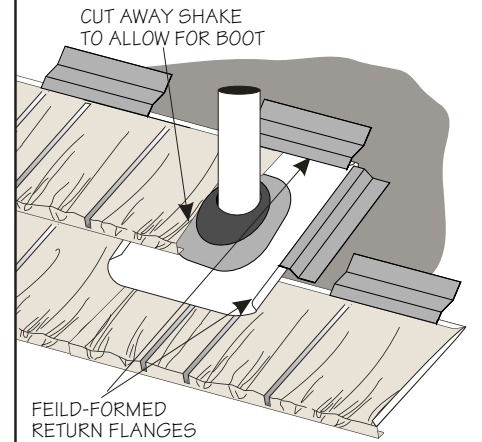

Illustration 6

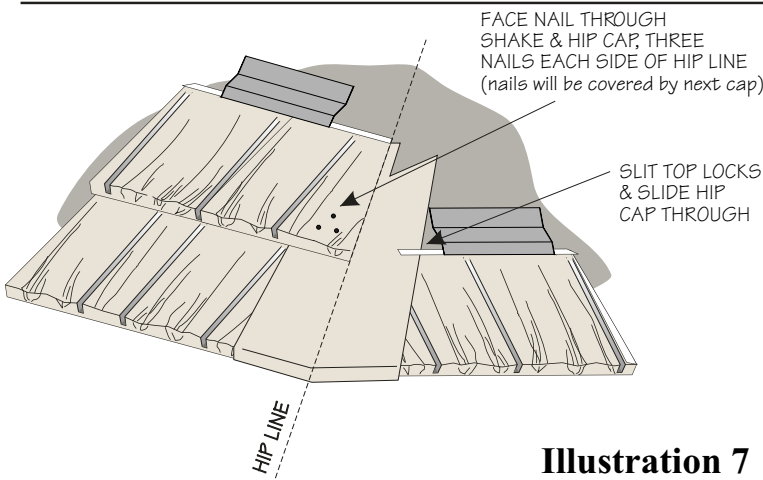

Illustration 7